



9400 Series Oval Flowmeter

- High accuracy
- Simple, durable construction
- Low maintenance requirements
- Easy access 3 piece design
- Choice of materials of construction
- Virtually pocketless design
- Virtually immune to viscosity changes

DESCRIPTION

The Brodie 9400 Series Oval Flowmeters, Models 9402 through 9459 (sizes 1/2" - 3"), are mechanical, positive displacement meters designed for use in the Chemical Processing, Industrial, Food and Beverage, and Hydrocarbon processing industries. Utilizing precision matched oval gears for exact liquid measurement, these highly accurate meters are virtually unaffected by changes in viscosity and maintain precision accuracy even when handling low viscosity products at low flow rates.

9400 Series Oval meters are supplied in a 3 piece design which uses both a top and bottom flange in place of the closed-end body configuration found on previous models. This 3 piece design meets or exceeds all of the design and performance specifications of the traditional oval while offering several distinct advantages.

The 3 piece Design:

- Allows service access from either side of the measuring chamber
- Provides access without interrupting electrical or mechanical connections to auxiliary equipment
- Allows easy access for visual inspection
- Improves the service life of the meter body

In addition to service features, the 3 piece design offers:

- A clean compact design
- Contoured flow paths for smooth liquid transitions
- Complete interchangeability with existing units
- Gear sets that are completely interchangeable

Reference bulletin X-9400 for complete installation and operating instructions.

Mechanical power transmission is established using a proven "Type 7" magnetic coupling to drive a variety of accessories in a number of applications. For applications requiring power generated operation reference DS-9800 Power Pulse Oval™ (sizes 1/2 to 3").



PRINCIPLE OF OPERATION

The Oval Flowmeter accurately measures liquid flow by using a slight pressure differential to rotate a pair of oval gears. The meshed gears seal the inlet from the outlet flow developing the pressure differential. When in the orientation as shown in Position 1, Figure 1, Gear A receives torque from the pressure difference, Gear B torsional forces cancel, and Gear A drives Gear B as depicted in Position 2. When Gear A rotates to the position as shown in number 3, it loses torque, but Gear B obtains torque and drives Gear A. This alternate driving action provides smooth rotation of almost constant torque without dead spots. Positions 4, 5, 6, 7, 8 and 9 illustrate this principle through a complete cycle bringing Gear A back to its original orientation as shown in Position 1.

As the gears rotate they trap precise quantities of liquid in the crescent shaped gaps or measuring chambers. The total quantity of flow for one rotation of the pair of oval gears is four times that of the rotational speed of the gears.

Because the amount of slippage between the oval gears and the measuring chamber wall is minimal, the meter is essentially unaffected by changes in viscosity and lubricity of the liquids.

An output shaft is rotated in direct proportion to the oval gears by means of a powerful magnetic coupling. The output shaft drives a gear train that provides meter registration in engineering units of gallons, liters, pounds, etc.

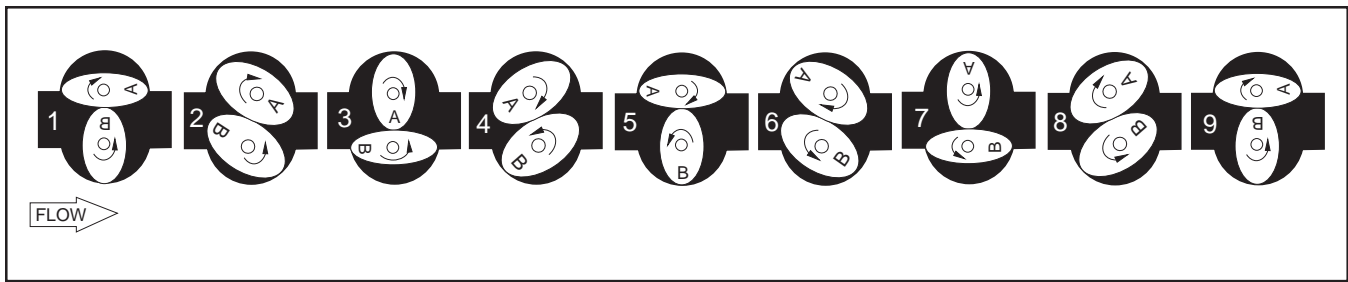

Figure 1 Principle of Operation

SPECIFICATIONS

⚠ WARNING

Do not operate this instrument in excess of the specifications listed below. Failure to heed this warning can result in serious personal injury and/or damage to the equipment.

Ratings:

Maximum Working Pressure

Flange Materials of Construction	ANSI Flange (lbs.)	Pressure Rating at 100°F (38°C)	
		psig	kPa
Steel	150 RF	285	1965
Steel	300 RF	740	5102
316 Stn. Stl.	150 RF	285	1965
316 Stn. Stl.	300 RF	740	5102

Strainer Specifications

Model Number	Connection Size	Mesh	Microns
9402	1/2"	80	150
9453	1"	80	150
9455	1"	60	250
9456	1-1/2"	60	250
9457	2"	40	350
9459	3"	40	350

Maximum Working Temperature

0°F to 230°F (-17°C to +110°C) Standard, Class "A"
230°F to 392°F (110°C to 200°C) Class "C" Option

Capacities

Refer to Table 1 (Reference Bulletin T-067 for comprehensive flow data)

Accuracy

±0.25% for viscosities of 5 centipoise and above on Class "A" meters only (Temperatures to 230°F or 110°C).
±0.5% on viscosities from 0.2 to 5 centipoise on Class "A" and Class "C" meters (Temperatures to 392°F or 200°C).

Performance

The Typical Performance Curves illustrated in Table 2 are representative of all meter sizes as determined through engineering testing. The Accuracy vs. Percent of Flow depicts variations in performance in relation to the lightest viscosity shown through the heaviest. Pressure Drop vs. Percent of Maximum Flow indicates the pressure drop of a typical meter when measuring various viscosities.

Pressure Drop

To assure maximum service life it is recommended that all Oval meters be sized for maximum flow with a pressure drop of less than 15 psi (103 kPa). As there is no significant shift in accuracy with a viscosity change of 100 centipoise it can be seen that the only limiting factor for higher viscosity change is Flow Range vs. Pressure Drop. Reference Bulletin T-067 for additional pressure drop information. Refer to Table 2.

Materials of Construction

Housing	Rotors	Shafts**	Bearings**	O-ring**
316 stn. stl.	316 stn. stl.	316 stn. stl.	Hard Carbon	Viton®
Cast Steel	316 stn. stl.	316 stn. stl.	Hard Carbon	Viton
Alloy 20*	Alloy 20*	Alloy 20*	Hard Carbon	Viton

*Available in Models 9402, 9453, 9455 and 9456 only.

**Standard components listed. See Model Code for options. Type 316 stn. stl. is Alloy CF-8M stn. stl. (Alloy 20 is Alloy CN-7M stn. stl.)

Dimensions

Refer to Figure 2. For certified dimension prints, consult factory.

"TYPE 7" MAGNETIC COUPLING

Mechanical power transmission is accomplished by magnetically connecting the output driving shaft of the meter to the driven shaft of the accessory block using a radial gap magnetic coupling (Type 7). Here the driving side of the coupling is exposed to the liquid product by way of the rotor shaft, but the driven side is isolated through the use of a sealed hollow shaft, allowing a dry, magnetic contact coupling. Thus the designation as a "pocketless," or "chemical" meter, ideal for liquid properties that are coagulative, viscous, dry or requiring periodic flushing or cleaning. Refer to Figure 3.

VISCOSITY

There are two basic classifications of viscosity; Standard (0.2 to 300 centipoise) and High (above 300 centipoise), each of which can be applied to the 9400 Series Oval Flowmeter.

Viscosity vs. Accuracy, Table 3: One unique advantage of the Oval principle is the ability to measure varying viscosities, within a given range, with only a slight shift in accuracy. Example: A meter calibrated for a product having a rating of 1.0 centipoise, then applied to a product having a rating of 100 centipoise will not shift in accuracy more than 1.2% above initial calibration.

Table 1 Capacities

Flowrange Capacities - USgpm

Connection Size	Model Number	Cold Water	Hot Water 140 to 230°F	LPG 0.2 cP	Gasoline 0.3 to 0.7 cP	Kerosene 0.7 to 1.8 cP	Light Oil 2 to 4 cP	Heavy Oil 5 to 300 cP
1/2"	9402	1.3 to 6.6	1.8 to 4.4	2.6 to 8	1.8 to 8	1.3 to 8	0.7 to 9	0.4 to 9
1"	9453	2.7 to 13.2	3.5 to 8.8	5.3 to 15.8	3.5 to 15.8	2.7 to 15.8	1.4 to 17.6	0.7 to 17.6
1"	9455	4 to 31	5 to 22	5 to 37	5 to 37	4 to 37	2 to 44	1 to 44
1-1/2"	9456	9 to 62	11 to 44	11 to 70	11 to 70	9 to 70	4 to 88	3 to 88
2"	9457	18 to 132	22 to 88	36 to 154	22 to 154	18 to 154	9 to 176	6 to 176
3"	9459	35 to 264	44 to 176	66 to 308	44 to 308	35 to 308	26 to 396	18 to 396

Flowrange Capacities - lpm

Connection Size	Model Number	Cold Water	Hot Water 140 to 230°F	LPG 0.2 cP	Gasoline 0.3 to 0.7 cP	Kerosene 0.7 to 1.8 cP	Light Oil 2 to 4 cP	Heavy Oil 5 to 300 cP
1/2"	9402	5 to 25	7 to 17	10 to 30	7 to 30	4.3 to 30	2.6 to 34	1.5 to 34
1"	9453	10 to 50	18 to 33	20 to 60	13 to 60	10 to 60	5 to 66	2.6 to 67
1"	9455	15 to 117	19 to 83	30 to 140	18 to 140	15 to 140	8 to 166	4 to 166
1-1/2"	9456	34 to 235	42 to 166	60 to 265	42 to 265	34 to 265	15 to 333	11 to 333
2"	9457	68 to 500	83 to 333	136 to 583	83 to 583	68 to 583	34 to 666	23 to 666
3"	9459	133 to 999	167 to 666	250 to 1166	167 to 1165	132 to 1165	98 to 1499	98 to 1499

Table 2 Characteristic Accuracy and Pressure Drop Curves

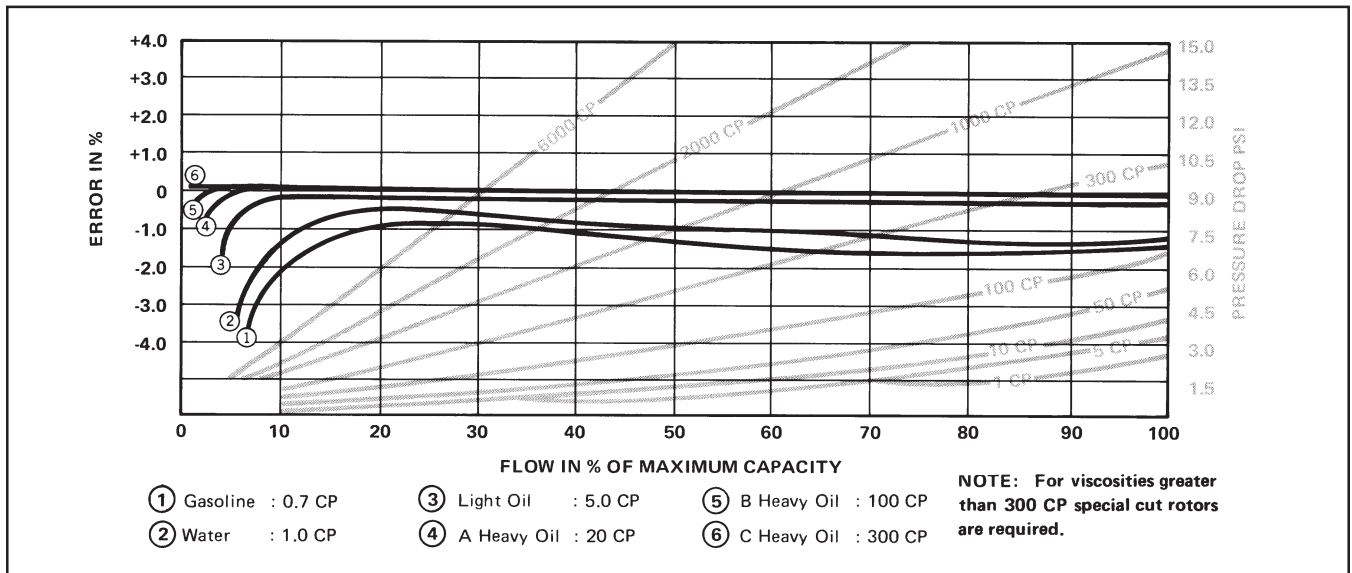

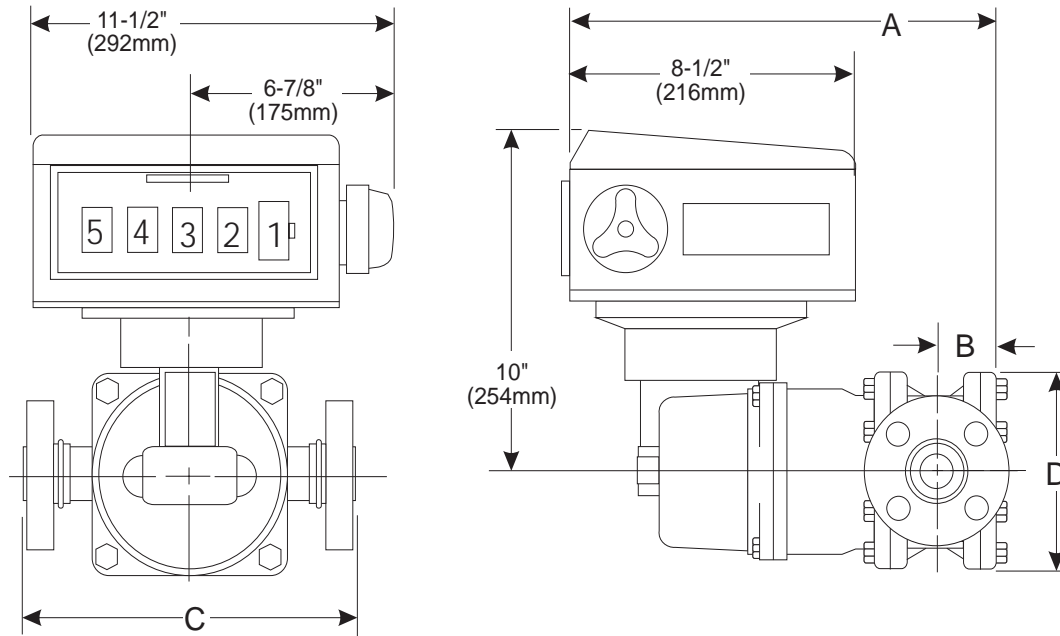

MODEL	SIZE	ANSI FLG. RATING	DIMENSIONS			
			A	B	C	D
9402	1/2"	150 lb.	10-5/16"	1-1/16"	8-3/4"	5-1/8"
		(1034 kPa)	(270mm)	(27mm)	(222mm)	(130mm)
9453	1"	150 lb.	11-1/2"	1-1/2"	8-3/4"	5-1/8"
		(1034 kPa)	(292mm)	(39mm)	(222mm)	(130mm)
9455	1"	150 lb.	14-3/8"	1-15/16"	8-3/4"	5-15/16"
		(1034 kPa)	(364mm)	(48mm)	(222mm)	(150mm)
	1"	300 lb.	14-3/8"	1-15/16"	8-3/4"	5-15/16"
		(2068 kPa)	(364mm)	(48mm)	(222mm)	(150mm)
9456	1-1/2"	150 lb.	15-1/2"	2-1/2"	10"	6-3/4"
		(1034 kPa)	(394mm)	(64mm)	(254mm)	(171mm)
	1-1/2"	300 lb.	15-1/2"	2-1/2"	10"	6-3/4"
		(2068 kPa)	(394mm)	(64mm)	(254mm)	(171mm)
9457	2"	150 lb.	15-3/4"	3"	13-3/4"	9-15/16"
		(1034 kPa)	(400mm)	(66mm)	(349mm)	(252mm)
	2"	300 lb.	15-3/4"	3"	13-3/4"	9-15/16"
		(2068 kPa)	(400mm)	(66mm)	(349mm)	(252mm)
9459	3"	150 lb.	19-1/8"	4-9/16"	17-3/8"	13-3/4"
		(1034 kPa)	(486mm)	(116mm)	(441mm)	(349mm)
	3"	300 lb.	19-1/8"	4-9/16"	17-3/8"	13-3/4"
		(2068 kPa)	(486mm)	(116mm)	(441mm)	(349mm)

Figure 2 Dimensions - 9400 Series Oval Flowmeter

GENERAL APPLICATIONS

Food and Beverage Application

The Brodie 9400 Series Oval is available in a "Clean-In-Place" (C.I.P.) design, Figure 4, for use in the Food and Beverage Industry where various types of syrups and raw liquid products are to be measured. Tri-Clover connections and a quick disconnect rear cover allows ease of maintenance where steam cleaning is a requirement to guarantee sanitary service.

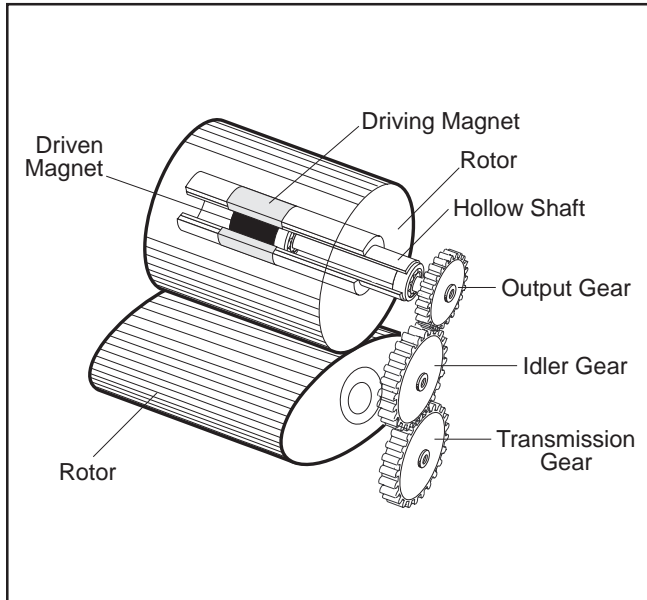

Figure 3 "Type 7" Magnetic Coupling

Special design features include:

- All 316 stainless steel construction
- Voidless Rotors
- Silicone O-rings
- Pocketless Design

Totalizing Flow: Volumetric measurement and inventory control may be obtained using the 9400 Series Oval Flowmeter in conjunction with a mechanical Large Dial Register (for local totalization), or may be electronically generated using a pulser. Refer to Figure 5.

Flow Rate Indication: Flow rate expressed in units per minute/hour can be achieved for local and/or remote indication using a combination of accessories. Refer to Figure 5.

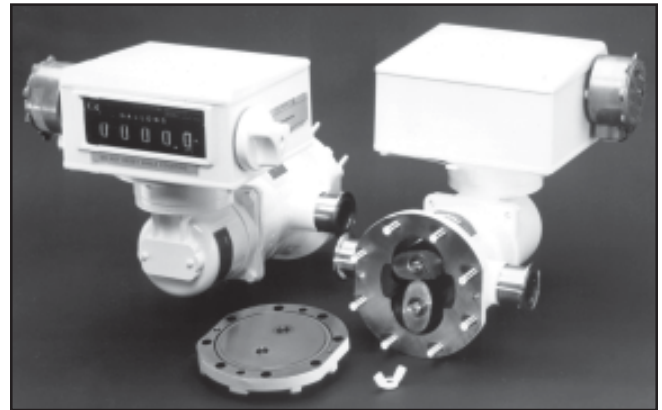
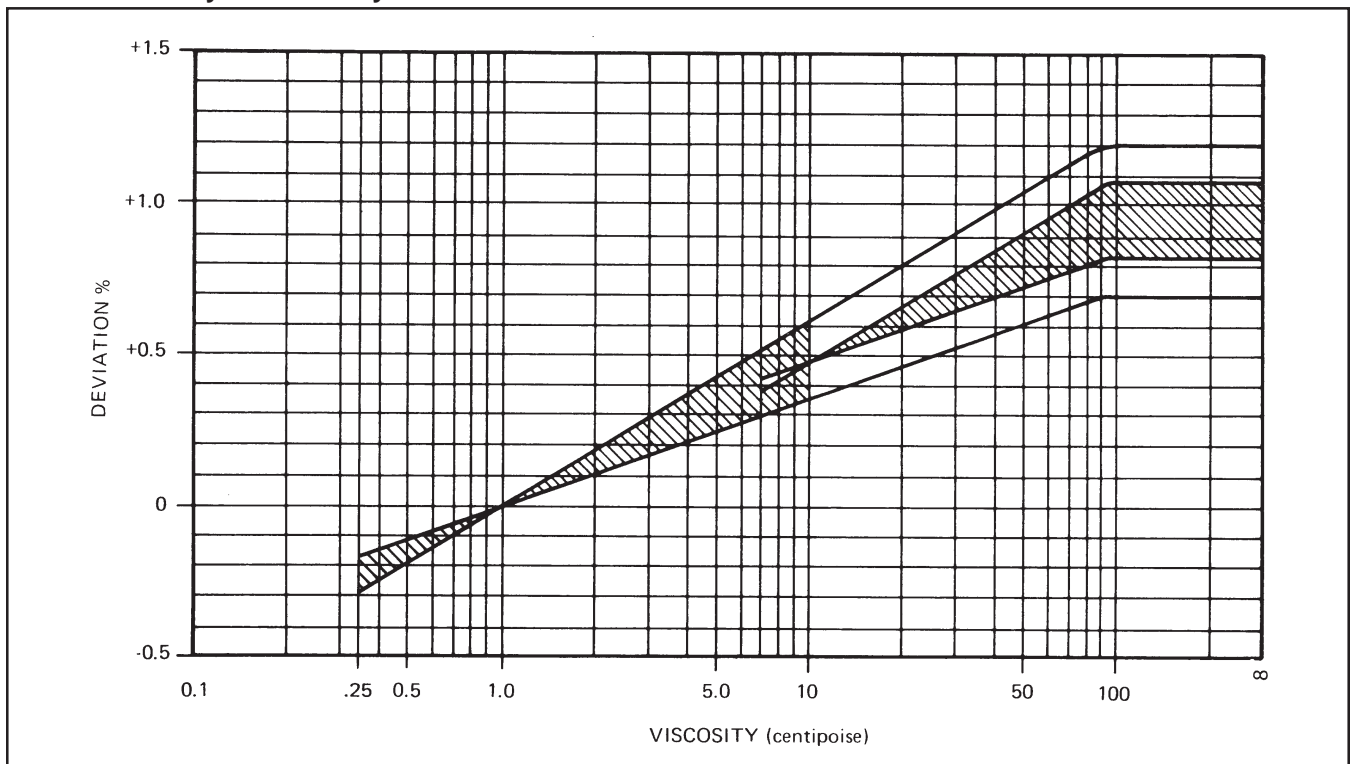

Figure 4 Clean-In-Place Oval Meter

Table 3 Accuracy vs. Viscosity - Oval Flowmeters with Class "A" Clearances



1. Large Dial Register with mercury wetted pulse transmitter and Low Frequency to Analog Converter with Indicator.
2. Large Dial Register with Electromechanical Flow Rate Indicator.

Batch Control: Automatic batch control is a feature of all Brodie products used in conjunction with specific pneumatic, mechanical and/or electrical accessories. In this operation a predetermined amount of liquid product is measured in preset quantities to fill a vessel, or to be blended with other products in specific combinations. Refer to Figure 5.

Flow Control and Recording: Some applications require that minimum and maximum flow rates be controlled to achieve set tolerances within a given system. Brodie 9400 Series Oval Flowmeters, used in combination with specific accessories, are designed to work within those given limits and to record rates as required. Refer to Figure 5.

ACCESSORIES

Refer to Figure 6.

ORDERING INFORMATION

In order to process an order, the following information must be supplied in addition to complete model number (Refer to Tables 4 and 5 for Ordering Information and Model Code):

1. Product to be metered
2. Product viscosity
3. Product temperature range
4. Rate of flow
5. Operating pressure
7. Units of Registration
8. Accessories and optional features

Table 4 Approximate Shipping Weight and Volume

Model	Shipping Weight	Shipping Volume
9402	33 lbs. (15 kg.)	1.58 ft ³ (.045 m ³)
9453	48 lbs. (22 kg.)	1.81 ft ³ (.051 m ³)
9455	64 lbs. (29 kg.)	1.93 ft ³ (.054 m ³)
9456	79 lbs. (36 kg.)	2.19 ft ³ (.062 m ³)
9457	159 lbs. (72 kg.)	2.99 ft ³ (.085 m ³)
9459	259 lbs. (118 kg.)	4.84 ft ³ (.137 m ³)

Specifications Subject to Change Without Notice

TRADEMARKS

Brooks.....Brooks Instrument Division, Emerson Electric Co.
 Brooks-Oval Brooks Instrument Division, Emerson Electric Co.
 Fisher-Rosemount Fisher-Rosemount Grp. of Companies
 Managing The Process Better Fisher-Rosemount Grp. of Companies
 Power Pulse Oval . Brooks Instrument Division, Emerson Electric Co.
 Teflon.....E.I. DuPont de Nemours & Co.
 Tri-10..... Brooks Instrument Division, Emerson Electric Co.
 Viton.....E.I. DuPont de Nemours & Co.
 Kalrez.....E.I. DuPont de Nemours & Co.

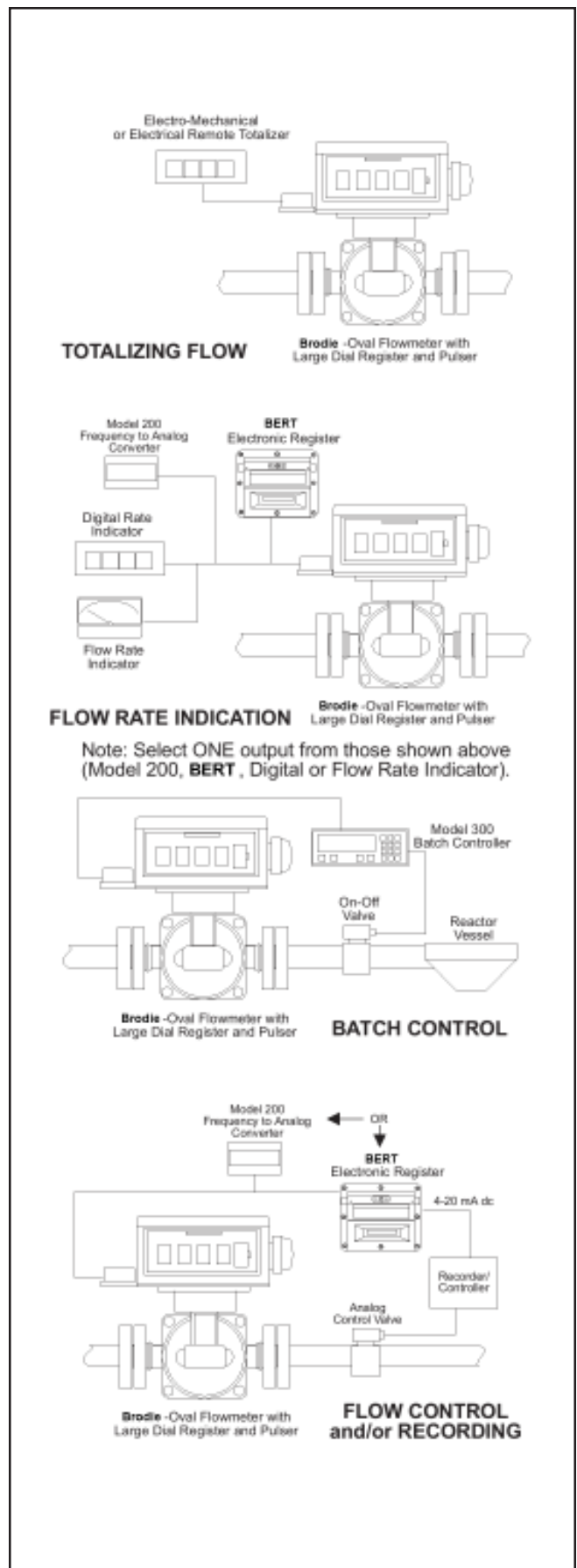

Figure 5 General Applications

Registration Accessories



Series 10 - Horizontal straight reading register (non-reset). Includes 6-digit totalizer with sweep hand. Records total volume passed through the meter.



Large Dial Register and Printer - Printer available as accumulative type (7-digit) to show batch size by totalizer differences. Zero start (6-digit) shows batch size directly without reference to totalized registration.

Large Dial Register - Large visible reset totalizing register featuring one-handed operation. Consists of a 5-digit reset totalizer and an 8-digit non-reset totalizer.



Large Dial Register, Printer and Preset - Fully automatic 4 or 5-digit mechanical preset for single or two-stage electric control. First stage is adjustable from 3 to 9, or from 20 to 90 by 10's. Final stage is trimmable to stop at zero. Electrical switches have two positions and 1-4 single pole, double throw (SPDT) switches. Printer is optional.



Vertical Dial Register - Straight reading non-reset register. It records in most any unit of measure (gallons, liters, barrels, etc.) of the total volume passed through the meter. Includes 7-digit totalizer with sweep hand. Options include a non-explosion proof magnetic reed switch capable of providing one or ten pulses per revolution of the register pointer.



Tri-10™ Electronic Register - a microprocessor based instrument used for flowrate indication, totalization and optional 4-20 mA output. This battery powered unit is encased in an explosion-proof, weatherproof NEMA 4X housing and may be used for integral or remote applications. Optional power source connections are available for 115/230 Vac and 24 Vdc operation. Loop powered analog units can operate from 10-30 Vdc.

All programming of the Tri-10 is accomplished through two push-button switches. In the operating mode, reset totals, gross totals or flowrate may be viewed sequentially by pressing a single button. Programming information and registered quantities are displayed on an 8-digit LCD viewing screen.

Batching Accessories



Oval Flowmeter for Electrical Predetermined Batching



Oval Flowmeter for Mechanical Predetermined Batching

Figure 6 Accessories

Table 5 Ordering Information and Model Code for sizes 1/2" to 3"

CODE		STANDARD SERIES NUMBER				
		CODE	METER SIZE			
		0 2	1/2"			
		5 3	1"			
		5 5	1"			
		5 6	1-1/2"			
		5 7	2"			
		5 9	3"			
		CODE	REVISION LEVEL			
		F	3-Piece			
		CODE	CONNECTION TYPE			
		B	150 lb. ASA R.F. Flange			
		D	300 lb. ASA R.F. Flange			
		H	Tri-Clover			
		Z	Other			
		CODE	COUPLING			
		7	Type 7			
		CODE	HOUSING MATERIAL			
		C	316 Stn. Stl.			
		D	Carbon Steel			
		F	Alloy 20			
		CODE	GEAR MATERIAL			
		1	316 Stn. Stl.			
		4	Voidless 316 Stn. Stl. (For C.I.P)			
		5	Alloy 20			
		CODE	GEAR ASSEMBLY CONSTRUCTION			
			Bearing	Magnet	Shaft	Visc.
		A	Carbon	Ceramic	Stn Stl.	Std.
		B	Carbon	Ceramic Hi-Temp.	Stn Stl.	Std.
		C	Carbon	Ceramic Encaps.	Stn Stl.	Std.
		L	Carbon	Ceramic	Stn Stl.	High
		M	Carbon	Ceramic Hi-Temp.	Stn Stl.	High
		N	Carbon	Ceramic Encaps.	Stn Stl.	High
		R	Waukesha	Ceramic	Chrome Pl.	Std.
		T	Waukesha	Ceramic	Chrome Pl.	High
		Z	Other	Other	Other	Other
		CODE	PACKING MATERIAL (O-rings)			
		2	Viton			
		3	Kalrez/Teflon			
		7	Silicon			
		8	EPR			
		9	Other			
		CODE	VARIATIONS			
		A	None			
		B	High Temp.			
		E	Thermonized (Std.)			
		F	Thermonized (High Temp.)			
		R	Dual Magnets in Rotor and Magnet Shaft			

9 4	5 5	A	B	7	C	1	A	2	A		A	Typical Part Number
-----	-----	---	---	---	---	---	---	---	---	--	---	---------------------



Brodie Meter Co., LLC

19267 Highway 301 North (30461)
 PO Box 450
 Statesboro, GA 30459-0450

Phone: (912) 489-0200
 Fax: (912) 489-0294
www.brodiemeter.com

The contents of this publication are presented for informational purposes only, and while every effort has been made to ensure their accuracy, they are not to be construed as warranties or guarantees, express or implied, regarding the products or services described herein or their use or applicability. Brodie Meter Co., LLC reserves the right to modify or improve the designs or specifications of such products at any time without notice.