

VERIS

*Superior Flow Measurement Accuracy
with No Straight Run Requirements and
Operating Ranges Never Before Attainable*

...Until Now

Introducing the New

Accelabar[®]



Accelabar... A New Idea in Flow Measurement

The Unique Accelabar Flow Meter

The Accelabar is a new and unique flow meter that combines two differential pressure technologies to produce operating ranges never before attainable in a single flow meter. It is capable of generating high differential pressures for measuring gas, liquids and steam at turndowns tested up to 65:1 with no straight run requirements.

How the Accelabar Works

The Accelabar consists of a unique toroidal nozzle design and a Verabar averaging pitot. The nozzle has a patented straight run "settling distance" that accelerates, linearizes and stabilizes the velocity profile sensed by the Verabar. The Verabar located within the nozzle accurately measures and significantly increases the differential pressure output to increase the operating range (turndown). The Accelabar has a constant flow coefficient and produces an accuracy of $\pm 0.50\%$ over the entire operating range (up to 65:1). *Other manufacturers claim high accuracy, but over a limited turndown.*

No Straight Run Required

The Accelabar can be used in extremely limited straight run piping configurations. The straight run is integral to the meter. The stabilization and linearization of the velocity profile within the throat of the nozzle eliminates the need for any upstream run.

Engineering Specifications

- Low velocity flow rates
- High accuracy: $\pm 0.50\%$
- Repeatability: $\pm 0.050\%$
- Verified flow coefficients
- No calibration required
- Extended turndown
- No straight run requirements
- Low permanent pressure loss
- Mass or volumetric flow

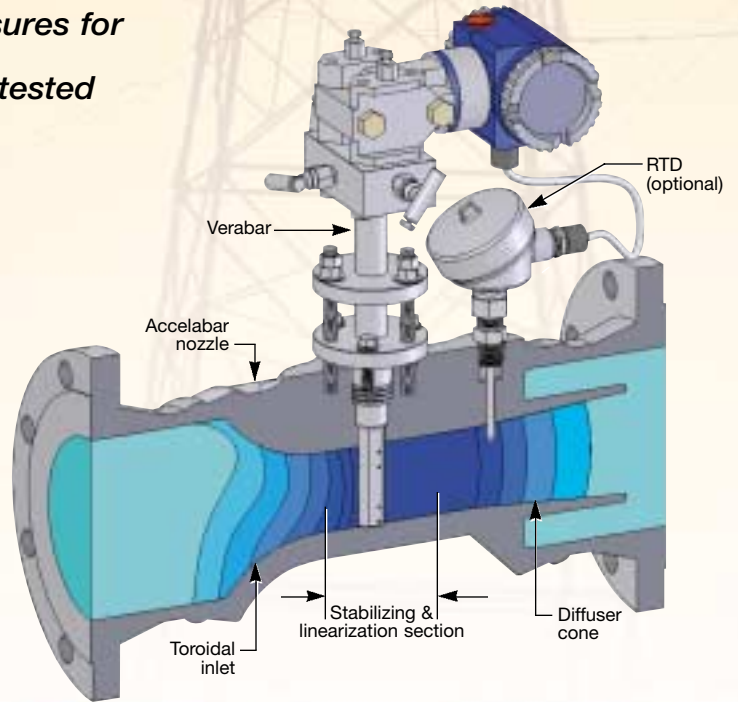

Actual Application

Application: 3" Sch 40 Natural Gas
Operating Pressure/ Temperature: 80 PSIG/70° F
Max/Min Flow Rate: 60,000 SCFH/1,000 SCFH
Flow Turndown: 60:1

* US Patent No. 6,868,741 B2 and various foreign patents pending.



Verabar Provides the Accuracy

The proven technology of the Verabar makes the Accelabar work. It accurately measures the flow rate within the nozzle. Its unique bullet shape, constant flow coefficient, solid one-piece construction, non-clog design and signal stability make it the only design capable of producing the overall performance.

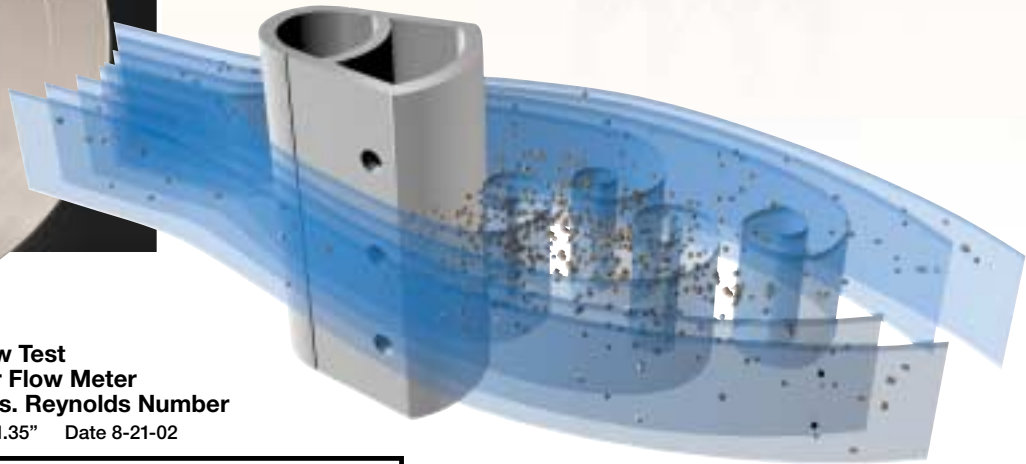

Flow Test
Accelabar Flow Meter
Flow Coefficient vs. Reynolds Number
Meter Diameter: 1.35" Date 8-21-02

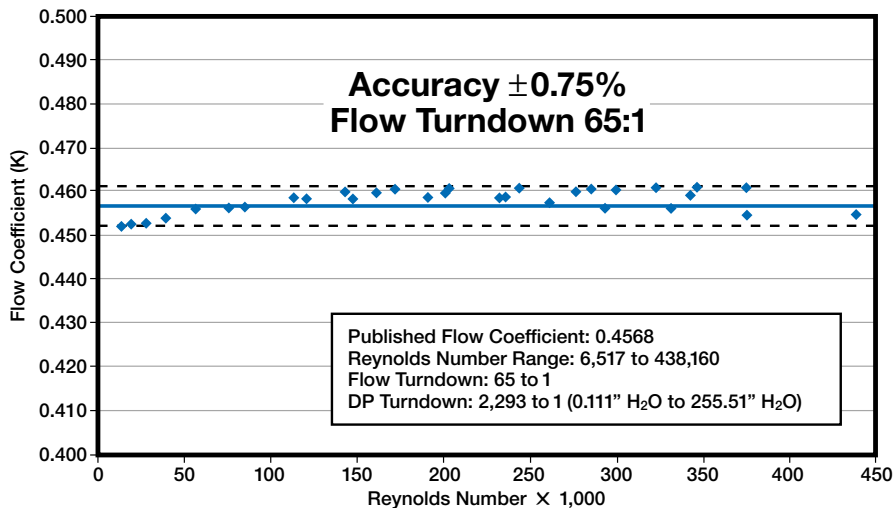

Verified Accuracy and Flow Coefficients

Empirical test data from independent laboratories verified an analytical model and flow coefficients as constant and independent of Reynolds Number and within $\pm 0.75\%$ of the predicted value over a flow turndown of 65:1 (see actual test). ***This eliminates the need for calibration.***

The Best Choice in Flow Meters

Comparative Analysis vs. Other Flow Meters

The Accelabar fills the need not presently being filled by other flow meters for applications that:

- Do not have sufficient velocity to produce a readable signal or sufficient turndown
- Require the highest accuracy over an extended range
- Have little or no straight run piping before the meter

The Accelabar performance characteristics far exceed those of other DP meters, vortex meters and many other flow meters.

These charts show the actual performance characteristics of the Accelabar versus other flow meters based on the following flow conditions:

Flow Conditions

Fluid	Air
Pipe Size	3" Sch 40
Max Flow	145 ACFM
SG	1.00
Pressure	60 psig
Temperature	75°F
Velocity	31 ft/sec

Accelabar Increased Velocity

Fluid Velocity — Pipe Line vs. Accelabar Throat

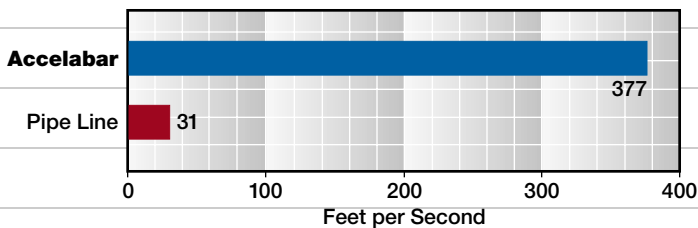

DP at Maximum Flow

Inches H₂O — 3" Air @ 145 ACFM

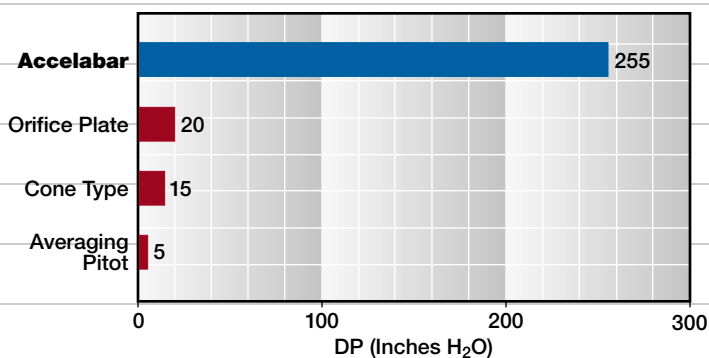

Flow Turndown

Maximum & Minimum

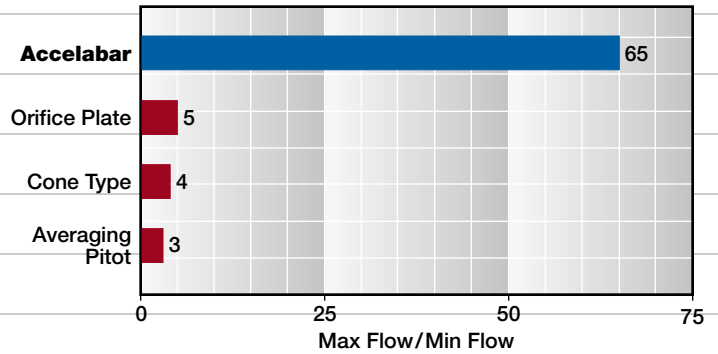

Flow Turndown

Accelabar vs. Vortex

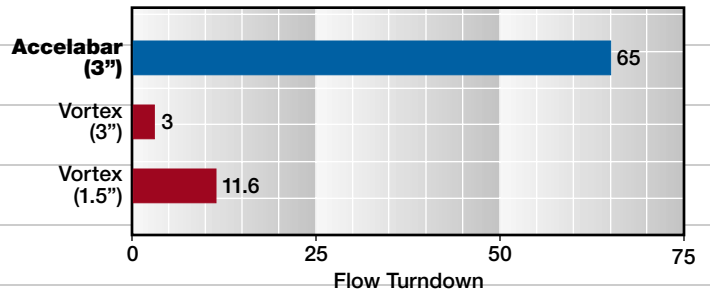

Minimum Straight Run Requirements

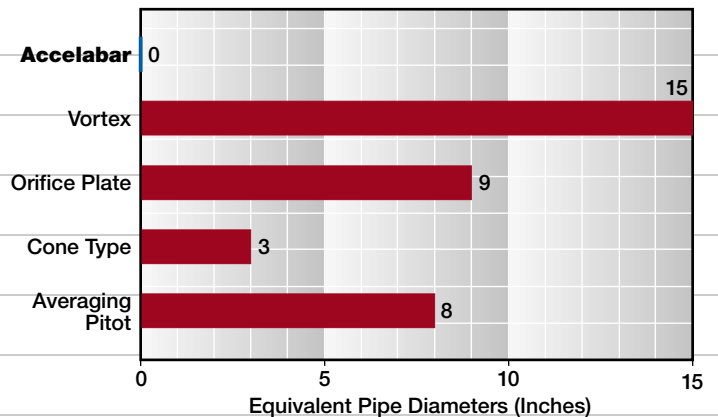

Permanent Pressure Loss

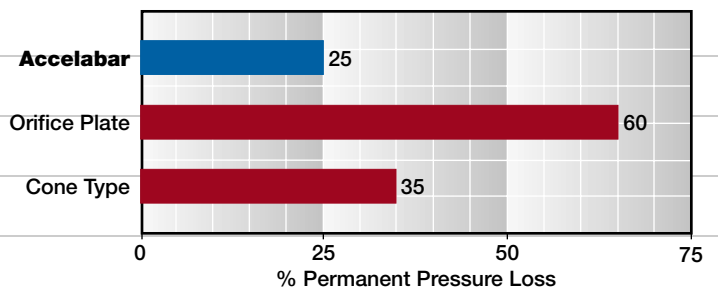

The Proof Is In The Data

Many flow meters claim high accuracy and rangeability or turndown. However, few manufacturers define their limitations and even fewer can support it with actual test data. The tests below show the performance capabilities of the Accelabar.

Turndown Test

Flow Test
Accelabar Flow Meter
Flow Coefficient vs. Reynolds Number
 Meter Diameter: 1.35" Date 8-21-02

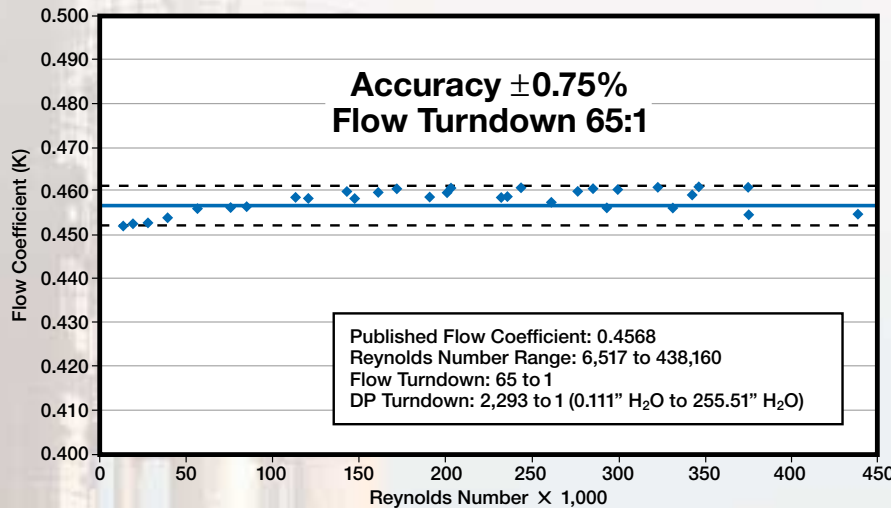

Test Specifications*

Pipe Size: 3" sch 40
 Fluid: Air
 Flow Rate: 145 ACFM
 Max Pressure: 60 psig
 Max Temperature: 75°F

Results

The Accelabar produced a DP of 255.5" H₂O at 145 ACFM. An accuracy of $\pm 0.75\%$ was maintained over a Reynolds Number range of 65 to 1. No other flow meter is capable of this operating range.

*Independent, NIST traceable tests were performed as follows:

- Air tests in 3", 4", 6" and 12" pipes
- NIST traceable water tests
- Large turndown natural gas testing
- Short straight-run testing

Consult factory for a copy of certified tests.

No Straight Run Test Comparison

Test Specifications

The Accelabar was tested immediately downstream of a valve, tee and expander assembly with no straight run upstream.

Flow Test
Accelabar Standard and Short Run Tests
Flow Coefficient vs. Equivalent Gas (mSCFD*)
 Meter Diameter: 1.35" Test Dates: 8-21-02, 11-7-02

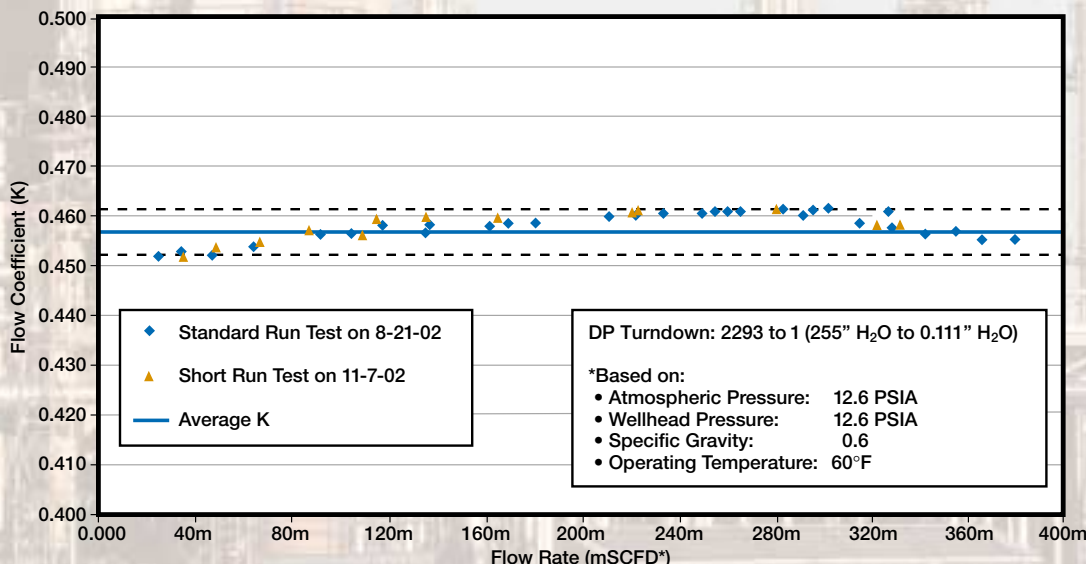

Results

The short run test plotted with the standard straight run test verifies there is no shift in the flow coefficient.



Models and Specifications

Ready to Install

The Accelabar is a complete flow meter ready to install. It comes complete with single or dual transmitters depending on the turndown requirements.

An optional RTD is supplied in a Thermowell for dynamic compensation (required for use with multivariable transmitter).

AF Flanged Model

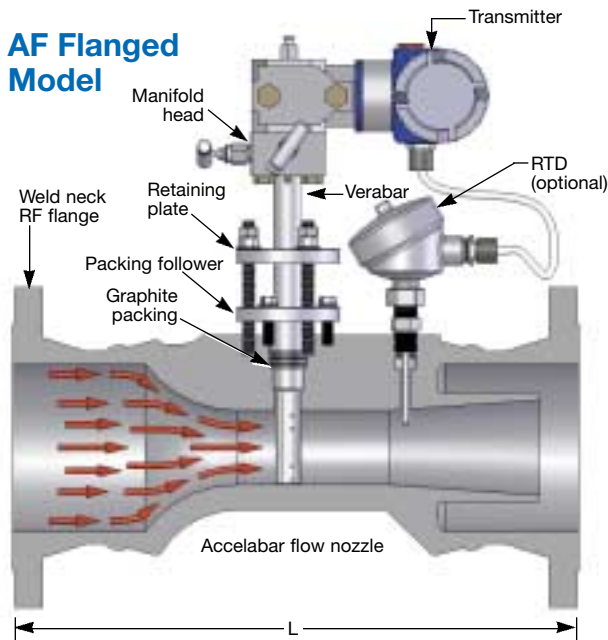

Accelabar Model Selection

1. Furnish your flowing conditions. A flow calculation is required to determine the DP and verification of the operating limits.
 - Each meter size has a standard beta ratio sized for the optimal operating range.
 - The maximum operating limits are determined by the Accelabar flow calculation.
2. If your flowing conditions exceed the operating limits, a larger or smaller model (meter size) must be selected.

Flowing Conditions

General Data	Fluid Parameters	Maximum	Normal	Minimum	Units
Tag number	Flow Rate				
Pipe size & schedule or exact ID & wall thickness	Pressure				
	Temperature				
Fluid name:	Density*				

*Density is not required for steam applications.

Dual Transmitter

Single Transmitter

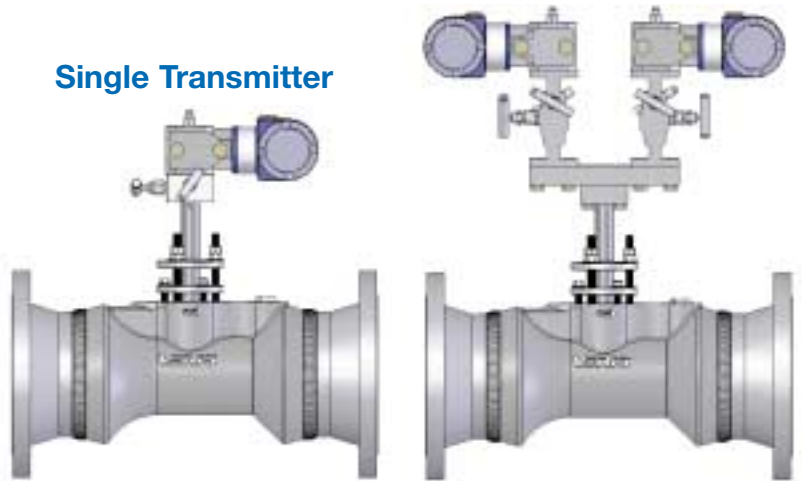

Chart A

Meter Size	Verabar Sensor	Face to Face "L"*		
		150#	300#	600#
3" (75mm)	-05 1/2"	13.78"	14.53"	15.28"
4" (100mm)	-05 1/2"	15.15"	15.90"	17.65"
6" (150mm)	-10 1"	19.15"	19.90"	21.90"
8" (200mm)	-10 1"	21.40"	22.15"	24.40"
10" (250mm)	-10 1"	23.15"	24.40"	27.65"
12" (300mm)	-10 1"	26.17"	27.78"	29.67"

* Face to face dimensions nominal. Custom lengths available.

Specifications

Accuracy	Repeatability	Sensor, Body & Flange
to $\pm 0.50\%$	$\pm 0.050\%$	316SS

Accelabar... The Right Choice

Transmitter Selection

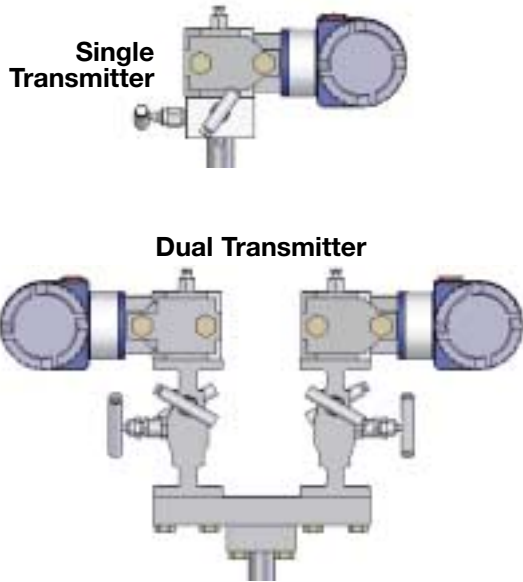

Code	Type Transmitter(s)
RG MT	Regular Multivariable
Transmitter(s) are calibrated based on your flowing conditions	
Code	Single and Dual (stacked) Transmitters
1	Single Transmitter
2	Dual (stacked) Transmitters for Direct Mount (F head only); includes Subplate and two Manifolds
3	Dual (stacked) Transmitters for Remote Mount (R head only); Manifolds not included and must be ordered separately
Code	Transmitter Output
MA	4-20 mA
HT	Digital Hart/4-20mA
Code	Optional Meter
LC	LCD Meter
Code	Transmitter Manufacturer
SV	Selected by Veris
SC	Selected by Customer - Designate manufacturer below

MT	1	HT	LC	SV	
-----------	----------	-----------	-----------	-----------	--

Installation Orientation

